



# Wetting of Fe–7.5%Cr steel by molten Pb and Pb–17Li

P. Protsenko<sup>a</sup>, A. Terlain<sup>b,\*</sup>, M. Jeymond<sup>a</sup>, N. Eustathopoulos<sup>a</sup>

<sup>a</sup> *Laboratoire de Thermodynamique et Physico-Chimie Métallurgiques, ENSEEG, INPG, BP. 75, 38402 Saint Martin d'Hères, France*

<sup>b</sup> *CEA-CEN Saclay/DEN/DPC/SCCME, 91191 Gif sur Yvette cedex, France*

## Abstract

Wetting of an Fe–7.5wt%Cr martensitic steel by molten lead has been studied as a function of temperature in the range 400–900 °C by the sessile drop and dispensed drop techniques. Two different furnace atmospheres (high vacuum and an He–H<sub>2</sub> gas mixture) and different heat treatments of the steel prior to test allowed the wetting for both oxidised and deoxidised steels. The influence of addition of Li, a metal with a high affinity for oxygen, to Pb on wetting has also been investigated.

© 2002 Elsevier Science B.V. All rights reserved.

## 1. Introduction

In fusion reactors, liquid metals or alloys are considered to be used as tritium breeding materials and/or coolants. For that purpose, the wetting and the reactivity of the liquid with the solid have to be characterised to assess the efficiency and lifetime of the system. For instance, extrapolation of corrosion data can only be done when the time for achieving the solid wetting by the liquid is known, otherwise an overestimation of the lifetime could be made. The cooling system efficiency depends on the wetting of the walls. The efficiency of some chemical processes basically depends on the mass transfer surface area which is closely related to the wetting characteristics of the solid by the liquid.

Oxide films on metallic or ceramic solids can improve the resistance to corrosion and embrittlement by liquid metals. However, an oxide layer is really protective only if it is not wetted by the liquid metal. Otherwise the liquid will penetrate through defects of the oxide films and contact the solid [1]. The wetting of both oxidised and deoxidised steel by Pb and Pb–17mol.%Li eutectic

alloy has been studied in the 400–900 °C temperature range.

## 2. Experimental procedure

Wetting is studied by the classical sessile drop and by the 'dispensed drop' techniques [2]. In both methods, wetting is characterised by the contact angle  $\theta$  formed by a liquid drop (L) on a smooth surface of the substrate (S) in a vapour phase (V) (Fig. 1). Measurements of  $\theta$  have been performed in an apparatus consisting of a molybdenum heater surrounded by molybdenum radiation shields, located in a water-cooled stainless steel chamber connected to a gas supply and a vacuum system. The chamber is fitted with two windows enabling the illumination of the sessile drop on the substrate. Images are obtained using a CCD camera and recorded on a videotape. Contact angles and linear dimensions (height and drop base diameter) of the drop are measured from the drop section image, with an accuracy of  $\pm 2^\circ$  and  $\pm 2\%$ , respectively.

Experiments are performed in a  $10^{-4}$ – $10^{-5}$  Pa high vacuum. For some experiments, a static atmosphere of one bar He–8% H<sub>2</sub> mixture passed through activated carbon cooled by liquid nitrogen (H<sub>2</sub>O < 0.4 ppm, O<sub>2</sub> < 0.1 ppm) was used.

The substrates used are  $12 \times 12 \times 1.5$  mm<sup>3</sup> martensitic steel platelets, containing 7.5 wt% (8.1 mol.%) Cr,

\* Corresponding author. Present address: CEA SACLAY, CEREM/DECM/SCECF, 91191 Gif sur Yvette cedex, France. Tel.: +33-1 69 08 16 18; fax: +33-1 69 08 15 86.

E-mail address: [anne.terlain@cea.fr](mailto:anne.terlain@cea.fr) (A. Terlain).

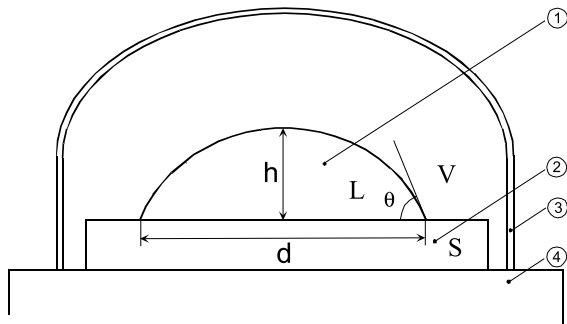

Fig. 1. Experimental set up: Pb droplet (1) on the steel substrate (2) covered by a quartz cup (3) on an alumina plate (4).  $\theta$ ,  $h$  and  $d$  are respectively the contact angle, the height and the diameter of the liquid droplet.

1.9% W, 0.2% V and less than 0.1% of C and Si. Substrates are mechanically ground and polished up to 1  $\mu\text{m}$  diamond paste in order to decrease the thickness of the oxide film eventually covering the substrate. The average roughness  $R_a$  of the polished surface is about 5 nm. The total roughness  $R_t$  is several tens of nanometers. It has been observed by XPS analysis and with this preparation method, that the steel surface is covered by an oxide layer of about 2 nm thick. Afterwards, a steel prepared by this procedure will be called 'oxidised steel'. Pure lead (99.999%) and Pb–17mol.%Li eutectic alloy are used for the preparation of millimetric size drops. The droplet weight is 50–100 mg.

A sessile drop experiment consists in putting a piece of lead on a steel substrate lying itself on an alumina plate in the isothermal zone of the furnace (Fig. 1). In order to limit the pollution of the furnace by evaporation of the liquid metal during heating in high vacuum, the piece of Pb on the steel substrate is placed under a quartz cup with polished bottom edges. In order to evacuate the air in the cap through the micron-size

capillaries formed between the quartz edges and the alumina plate, the furnace chamber is pumped during 12 h before heating. Thereafter time-dependent variation of the contact angle, drop base radius and height are monitored during temperature rise, isothermal holding and cooling.

In the dispensed drop technique, the drop is deposited in situ on the substrate at the experimental temperature. The metal is separately heated in an alumina crucible. Once the experimental temperature is reached, the liquid is extruded from the crucible (Fig. 2) and the capillary introducer is pushed down in order to initiate contact between the lower surface of the droplet and the substrate. Then the drop is spontaneously detached from the capillary, and spreading continues as in the classical sessile drop configuration. The experiments are carried out in a high vacuum at 400  $^{\circ}\text{C}$ , a temperature at which the Pb evaporation is negligible.

### 3. Results

Fig. 3 shows the time dependence of the contact angle (Fig. 3(a)) and linear dimensions (Fig. 3(b)) of a Pb drop on the steel substrate during a continuous rise of the temperature up to 800  $^{\circ}\text{C}$  (heating rate: 200  $^{\circ}\text{C h}^{-1}$ ) in a sessile drop experiment performed in high vacuum.  $\theta$  is the average of contact angles measured on the left and right sides of the drop. It can be distinguished between very high non-wetting ( $\theta > 90^{\circ}$ ) contact angles at low temperatures, contact angles close to  $\theta = 90^{\circ}$  at intermediate temperatures and finally, at higher temperatures, contact angles close to 60 $^{\circ}$ . All the contact angles were obtained during an increase of the drop base radius. At 800  $^{\circ}\text{C}$  an important evaporation of liquid metal occurs as shown by the simultaneous decrease of the drop base radius  $d$  and the height  $h$  at nearly constant  $\theta$ . No dewetting is observed during cooling.

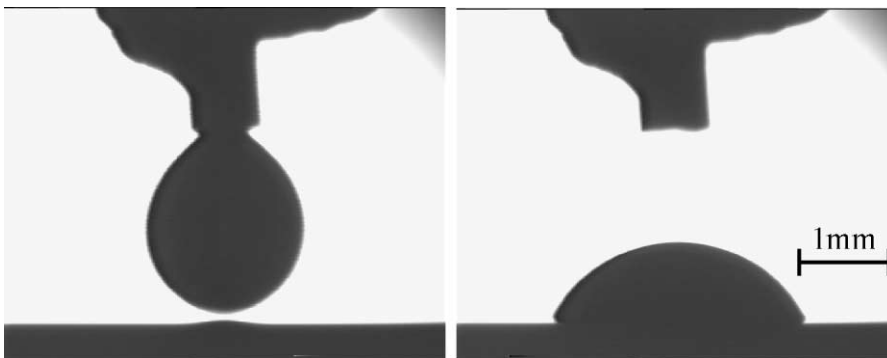

Fig. 2. Formation of a Pb drop by extrusion of the liquid through a capillary (left) and spreading on a stainless steel surface at 400  $^{\circ}\text{C}$  in high vacuum. In this experiment, the furnace was heated at 850  $^{\circ}\text{C}$  in high vacuum before the drop formation. Drop base diameter  $d = 2.75$  mm.

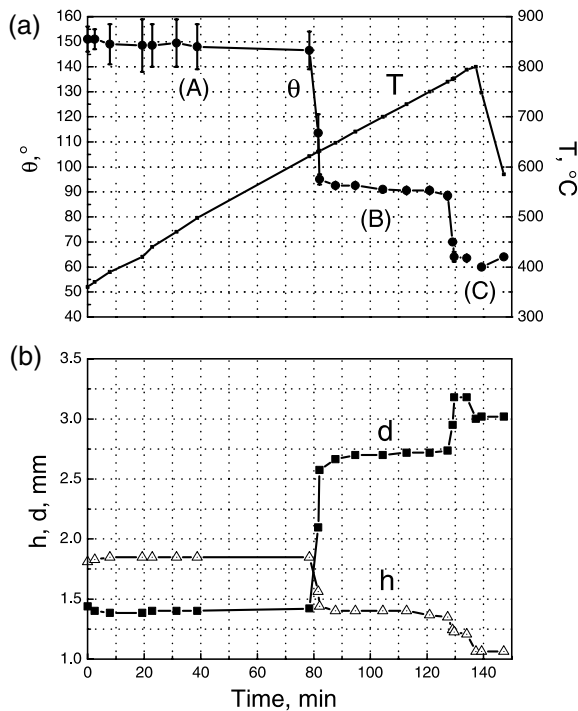

Fig. 3. Contact angle  $\theta$  (a) and height,  $h$ , and diameter,  $d$ , of a liquid droplet (b) of a sessile drop versus time during a temperature cycle for pure lead on a stainless steel substrate studied in high vacuum using the configuration of Fig. 1.

Further experiments were performed with the dispensed drop technique by heating a steel substrate in high vacuum at 400 °C and then depositing on it a Pb drop. The resulting contact angle is close to 90° as in the domain B (Fig. 3, Table 1). However, when the dispensed drop experiment at  $T = 400$  °C is performed with a substrate preheated in situ at 850 °C in high vacuum, a contact angle of about 60° (Fig. 2 and Table 1) is observed in less than 40 ms and remains constant during the whole experiment (2000 s). This value is close to the contact angles measured in domain C.

Table 1  
Contact angles of molten Pb and Pb–17mol.%Li drops on steel at 400 °C in a  $10^{-5}$  Pa atmosphere, obtained with the dispensed drop technique

Liquid	Contact angle (deg.)	
	Oxidised steel	Deoxidised steel <sup>a</sup>
Pb	$(91 \pm 2)^\circ$	$(60 \pm 3)^\circ$
Pb–17mol.%Li	$(68 \pm 2)^\circ$	$(62 \pm 4)^\circ$

<sup>a</sup> Heat treated at 850 °C in high vacuum.

The SEM examination of the Pb–steel interface after heating in domain C for a few minutes did not reveal any reactivity and the interface appeared flat in the scale of 0.1  $\mu\text{m}$ . After 15 min at 850 °C, which is a time much longer than the time needed for the drop to reach a stationary contact angle, small ( $\approx 150$  nm) grain boundary grooves were observed. No such grooves are observed by SEM on steel preheated at 850 °C and then held at 400 °C for several hours in contact with Pb.

Two further experiments were performed in a static He–8%H<sub>2</sub> atmosphere using the sessile drop technique. At 550 °C, the contact angles were found to be equal to 140° and 123°. They hardly changed by increasing the temperature to 900 °C. After the experiments, the steel surface was found to be oxidised.

The addition of 17 mol.% Li in Pb has a negligible effect at 400 °C in high vacuum on the contact angle of a Pb drop deposited by using the dispensed drop technique on steel preheated at 850 °C. But it induces a large decrease of  $\theta$  on the steel directly heated at 400 °C (by 20°, see Table 1). In both cases, the stationary contact angles were reached in less than 40 ms. As for Pb, the reactivity at the Pb–Li/steel interface at 400 °C is negligible.

#### 4. Discussion

Contact angles close to 150° observed at low temperatures (domain A) are much higher than those observed for non-reactive liquid metals on solid metals (for which  $\theta \ll 90^\circ$ ) and even on ionocovalent oxides ( $\theta \approx 120^\circ\text{--}130^\circ$ ) [2]. Actually it has been shown [3] that such high contact angles are due to oxide skins formed at the liquid metal surface inhibiting the movement of the solid–liquid–vapour triple line. In our experiments, the oxidation of Pb was evident because at melting and in the whole A domain, the surface of the liquid was not smooth. Consequently, contact angles measured in domain A are only apparent.

True contact angles of Pb on the steel in the low temperature domain were measured by the dispensed drop technique, in which the oxide skin is broken during the formation of the droplet. The resulting contact angle, close to 90° as in the domain B (Table 1), can be attributed to the contact angle of deoxidised Pb on an oxidised steel surface in high vacuum. Further, the contact angles close to 60° observed at  $T \geq 800$  °C (Fig. 3) or at 400 °C on steel substrates preheated at 850 °C (dispensed drop experiments, Table 1) are attributed to a deoxidised (metallic character) steel surface.

In the absence of an oxide layer on the steel, Li can hardly affect the wettability of steel by Pb (Table 1). Indeed both the surface tension of Pb and Li (respectively equal to 454 and 369 mJ/m<sup>2</sup> at 400 °C [2]) and the affinity of these metals for Fe and Cr are similar. For

instance, the maximum solubility of Fe in molten Li at 900 °C (no data are available at lower temperatures) is between  $10^{-2}$  and  $10^{-3}$  mol.% [4] which is close to the values for molten Pb (about  $10^{-2}$  mol.% [5]). In the case of an oxidised steel the key factor to consider is the affinity of Li for oxygen. It is much higher than the affinity of Pb for oxygen as shown by the values of the standard Gibbs energy of formation (per oxygen gram atom) of  $\text{Li}_2\text{O}$  (–512 kJ) and  $\text{PbO}$  (–152 kJ) at 400 °C. Li may improve the wetting by chemisorption at the Pb/oxide interface in a similar way as Al in  $\text{Cu}/\text{Al}_2\text{O}_3$  [2,6] or Mg in  $\text{Pd}/\text{MgO}$  [7] systems. Note that it does not mean that a reaction does not take place at the interface but only that the new oxide ( $\text{Li}_2\text{O}$  or a complex oxide of Li) is not better wetted than the initial one.

An interesting and rather surprising result is the value  $\theta \approx 90^\circ$  observed for pure Pb on oxidised steel in high vacuum. This value is lower by more than  $30^\circ$  than those observed ( $123^\circ$ – $140^\circ$ ) on the oxidised steel in  $\text{He}$ –8% $\text{H}_2$ . We attribute this difference to the difference in the oxide layer thickness on the steel samples. For thick oxide films, as those obtained in  $\text{He}$ –8% $\text{H}_2$  (with an oxygen partial pressure about  $10^{-15}$  Pa, low enough to obtain a deoxidation of Pb at 550 °C but much higher than the value  $10^{-34}$  Pa needed to deoxidise the stainless steel). In this case, the physico-chemical and energetic properties of the oxide surface at a given temperature are controlled by the level of  $p(\text{O}_2)$  in the gas. However, for films of nanometric thickness, as those observed on steel in high vacuum, the presence of a strongly reducing element as Cr (the value of  $p(\text{O}_2)$  for  $\text{Cr}/\text{Cr}_2\text{O}_3$  at 400 °C is as low as  $10^{-45}$  Pa) in the immediate vicinity of the film, may profoundly affect the chemistry and structure of the thin oxide layer. Such an effect has been reported for  $\alpha\text{-Al}_2\text{O}_3$  in the presence of Al or Si which are also strong reducing elements. Bulk alumina has a negligible non-stoichiometry range, but in the presence of Al or Si, (0001) faces of  $\text{Al}_2\text{O}_3$  loose oxygen and exhibit a two-dimensional reconstruction of the surface [8,9] responsible for an important improvement of its wettability by molten metals [10,11].

## 5. Conclusion

The film covering martensitic steel surfaces in contact with air at room temperature can be removed by heating at 850 °C under high vacuum.

In high vacuum, pure lead wets deoxidised steel (contact angle  $\theta \approx 60^\circ$ ) but it does not wet oxidised steel. However, in the last case the  $\theta$  value lies very close to the non-wetting  $\rightarrow$  wetting transition value of  $90^\circ$ . The addition of Li to Pb does not affect the wetting of deoxidised steel by Pb but it decreases the contact angle of Pb on oxidised steel by more than  $20^\circ$  and therefore improves the steel wetting.

An important difference in the contact angle of pure Pb on oxidised steel has been found between experiments performed in high vacuum ( $\theta \approx 90^\circ$ ) and in  $\text{He}$ – $\text{H}_2$  ( $\theta \approx 130^\circ$ ). This difference is attributed to different values of oxygen partial pressure in the vicinity of the oxidised surface of steels used in these two types of experiments.

## References

- [1] J.C. Ambrose, M. Nicholas, *Met. Sci. Technol.* 12 (1996) 72.
- [2] N. Eustathopoulos, M. Nicholas, B. Drevet, *Wettability at High Temperatures*, Pergamon, Oxford, 1999.
- [3] I. Rivollet, D. Chatain, N. Eustathopoulos, *Acta Metall.* 35 (1987) 83.
- [4] T.B. Massalski (Ed.), *Binary Alloy Phase Diagrams*, 2nd Edn., ASM International, 1990, p. 1718.
- [5] J.R. Weeks, A.J. Romano, *Corrosion – NACE* 25 (3) (1969) 131.
- [6] L. Labrousse, thesis, Institut National Polytechnique de Grenoble, November 2000.
- [7] I. Guesdon, thesis, Institut National Polytechnique de Grenoble, November 1999.
- [8] T.M. French, G.A. Samorjai, *J. Phys. Chem.* 74 (1970) 2489.
- [9] E. Gillet, B. Ealet, *Surf. Sci.* 273 (1992) 427.
- [10] J.J. Brennand, J.A. Pask, *J. Am. Ceram. Soc.* 51 (1968) 569.
- [11] N. Eustathopoulos, B. Drevet, *Mater. Sci. Eng. A* 249 (1998) 176.